

Drying cabinet

TS4121

Features

- The drying cabinet is working with negative pressure which eliminates leakage of air into the room
- Dual fans and air ducts give perfect air balance and an even drying result in the whole cabinet
- 18 pivoting hanging rolls made of anodized and painted tubing
- Automatic drying program
- Adjustable floor supports – for easy installation
- Large doors and opening angle – for easy use



Main specifications		TS4121
Loading capacity	kg	6-8
Drying capacity*	g/min	72
Drying time	min	45
Heating effect	kW	6
Heat pump	kW	–
Energy consumption/kg	kWh	0.7
Energi kWh/litre evaporated water	kWh	1.32

* The time is valid for 6 kgs of cotton with a moisture retention of 55%.

Electrical connections	TS4121	
Voltage	400V 3N AC 50 Hz	kW(A)
		6.2(10)
Connections		
Air outlet	∅ mm	125
Evacuated air	Max. m ³ /h	250
Pressure drop*	Max. Pa	70
Shipping data		
	net, kg	127
Dimensions in mm		
A Width		1195
B Depth		580
C Height		1820
D		1565
E		255
F		820
G		510
H		205
I		595
1 Control panel 2 Electrical connections 3 Exhaust connection		

* Equal to ∅125 mm is equal to 23 m straight pipe.
Using ∅160 mm exhaust pipe is equal to 70 m straight pipe.

NOTE! The drying cabinet has to be fixed to a wall.

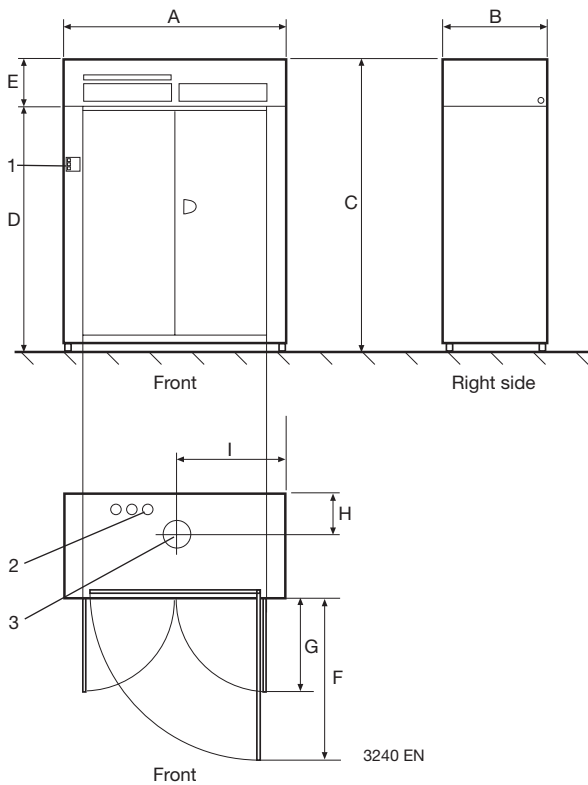

Thinking of you
Electrolux

www.electrolux.com/professional

Share more of our thinking at www.electrolux.com